

ACO ShowerDrain S+

DN 50 / стандартная высота сифора

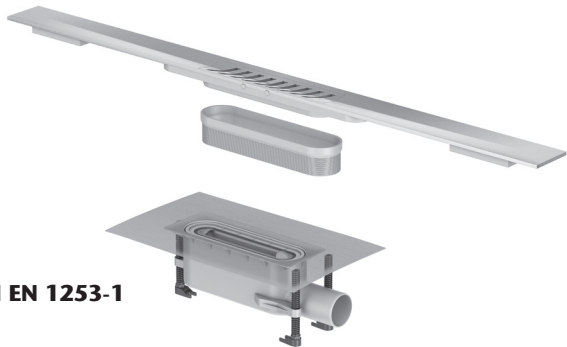

DN 50 / низкий сифон

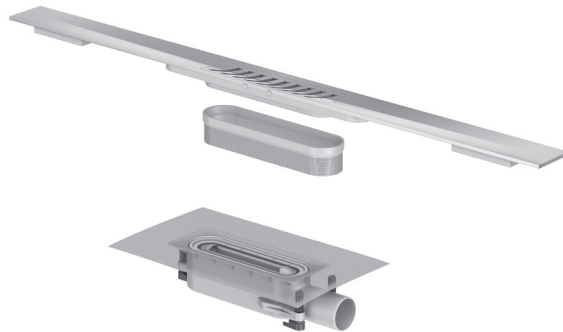

2021-05-18

Инструкция по монтажу душевого канала
ACO ShowerDrain S+



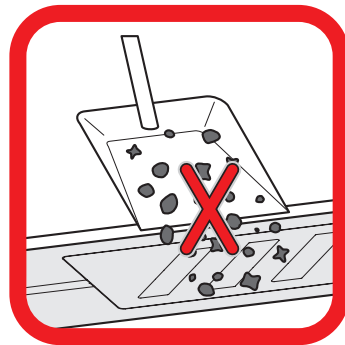
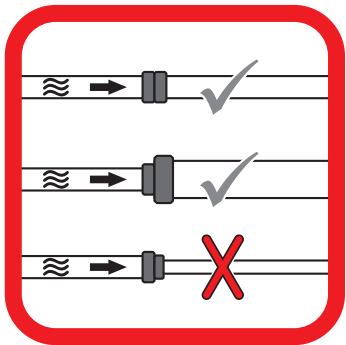
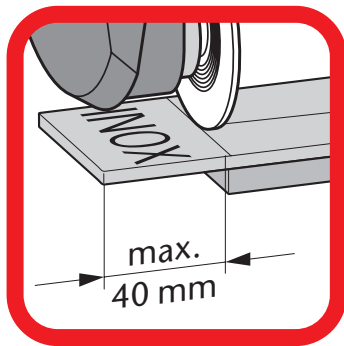

Inhalt Content



Benötigte Werkzeuge / Required Tools	3
Einbauhöhe / Installation Height	4



Montage der ShowerDrain S+ / Assembling the ShowerDrain S+	5
--	---



Verlegung der Fliesen / Laying the Tiles	10
--	----



Wartung / Maintenance	18
-----------------------------	----

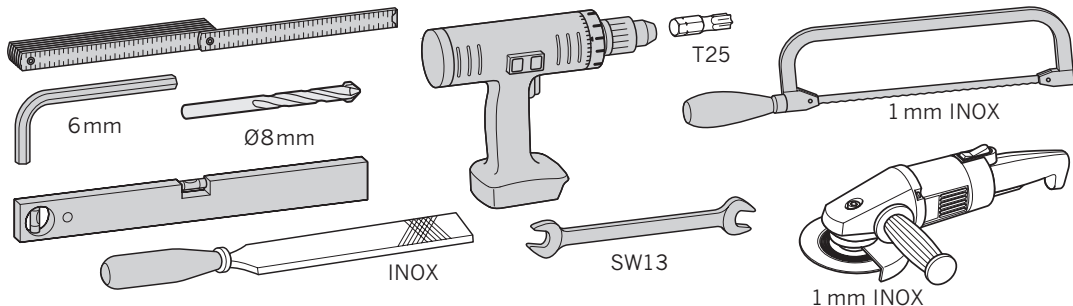



GV 50
WS 50

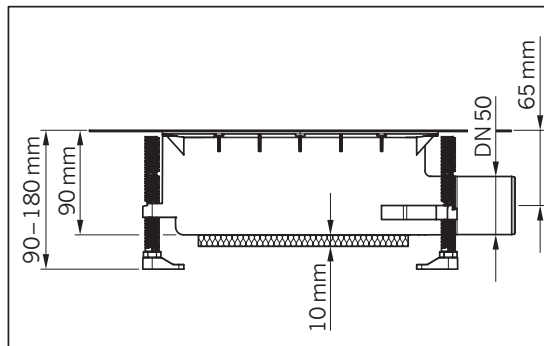

GV 30
WS 30

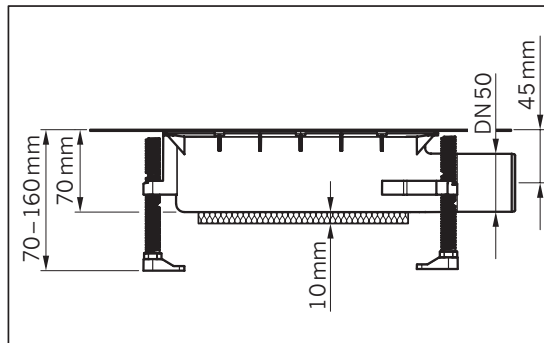
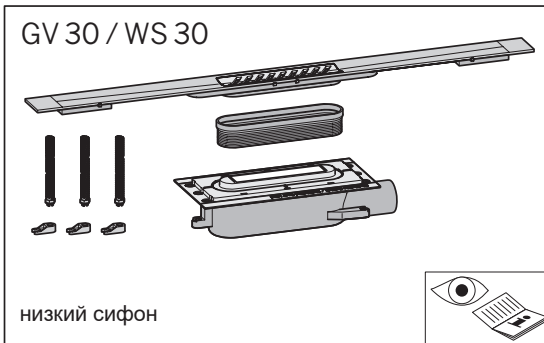

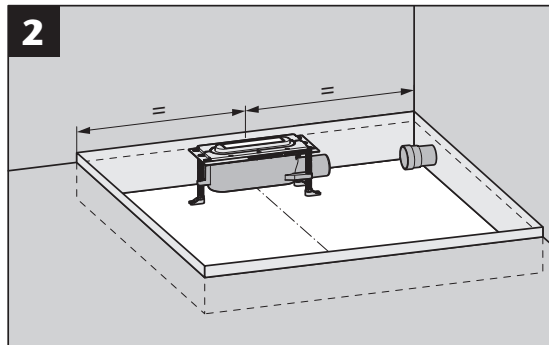
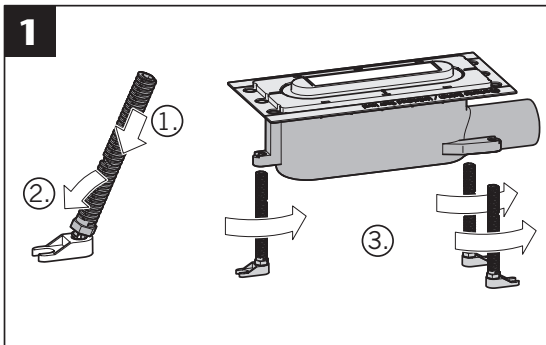



3a...3d

Только для
установки около
стены

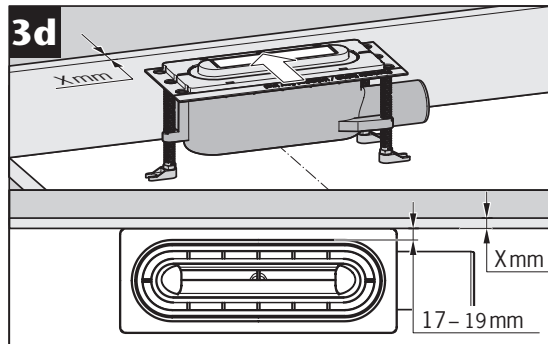
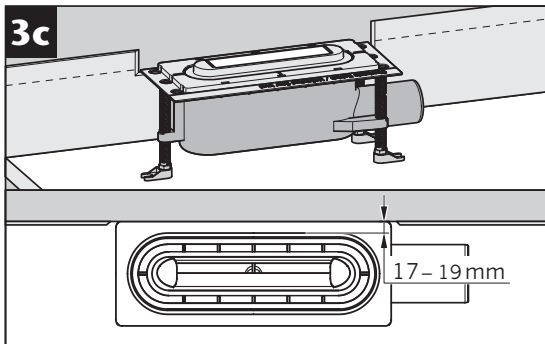
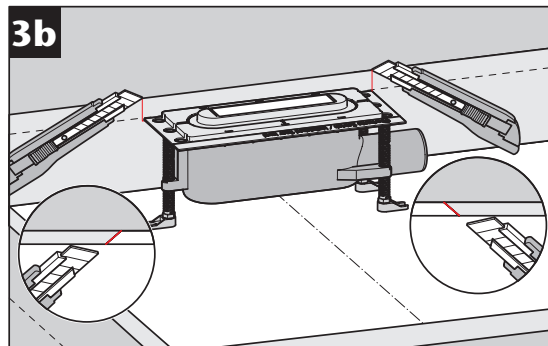
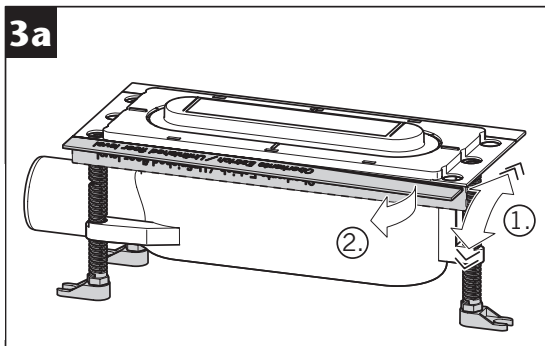

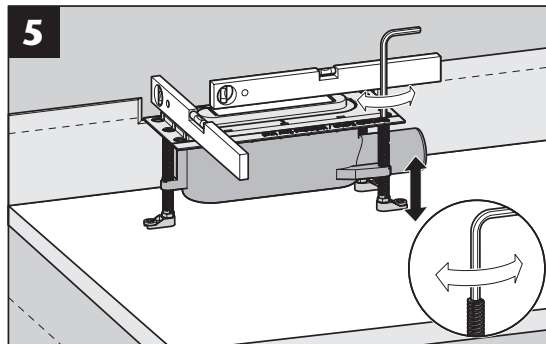
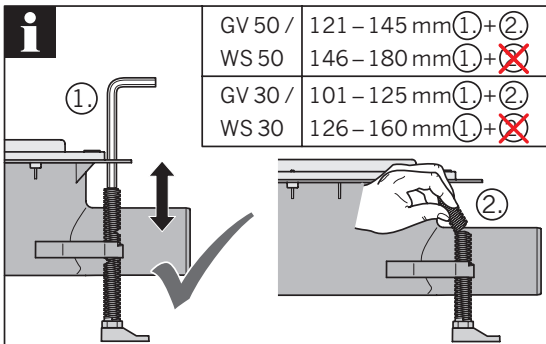
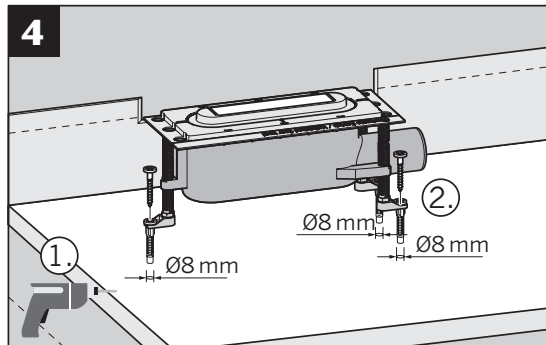
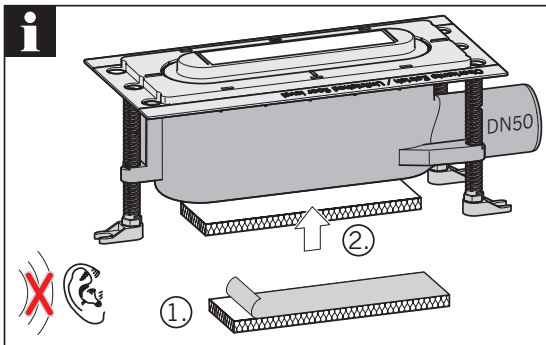

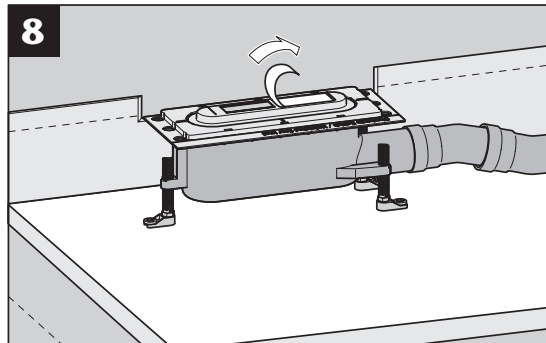
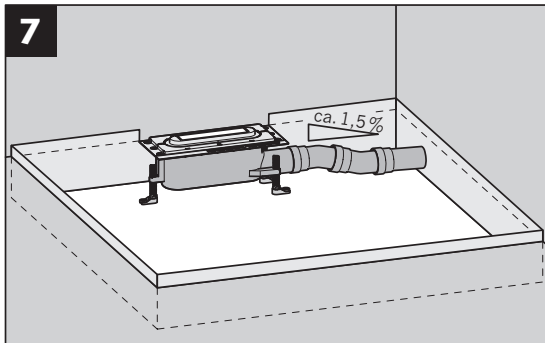
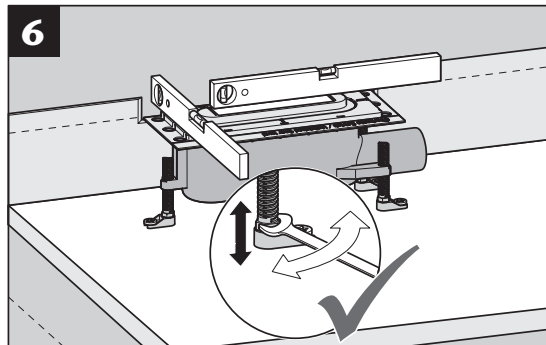
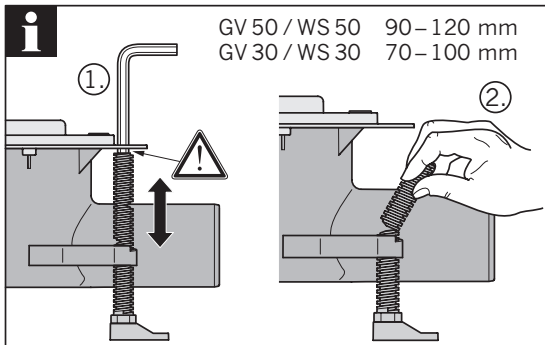

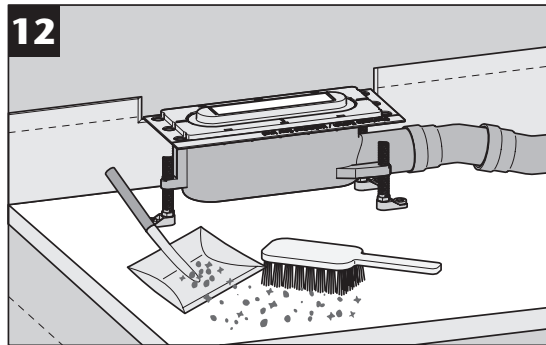
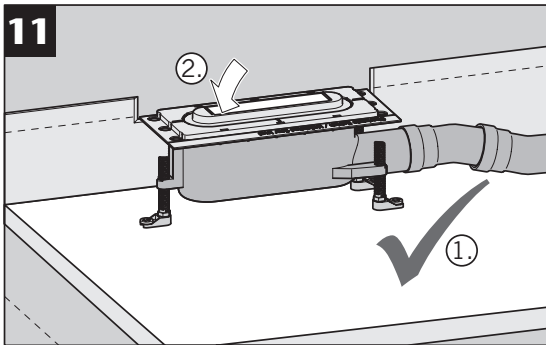
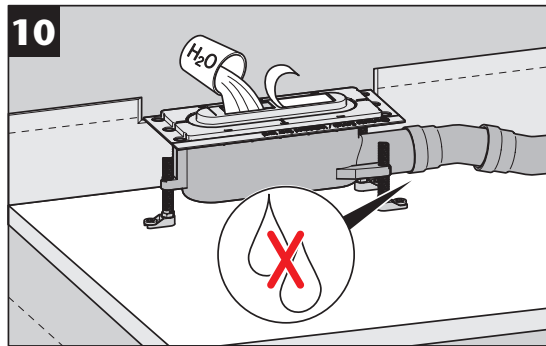
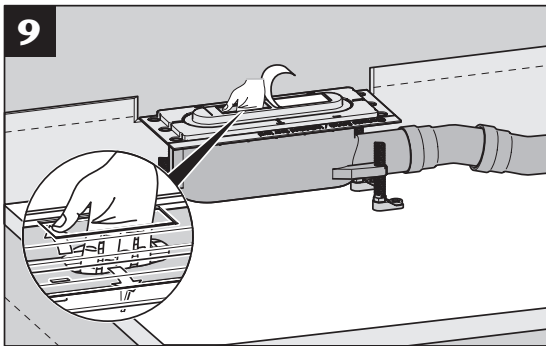



- * Hohlraumfrei unterfüttern
- * Lining without cavities

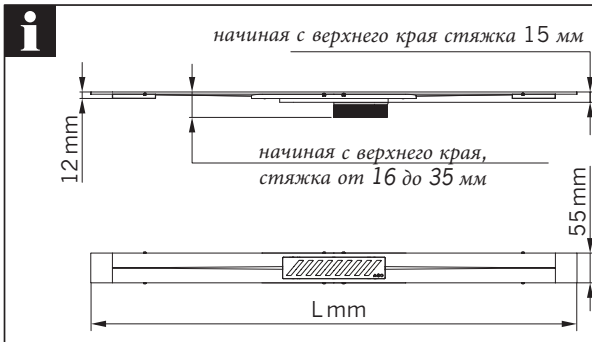
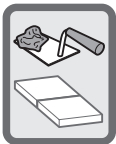
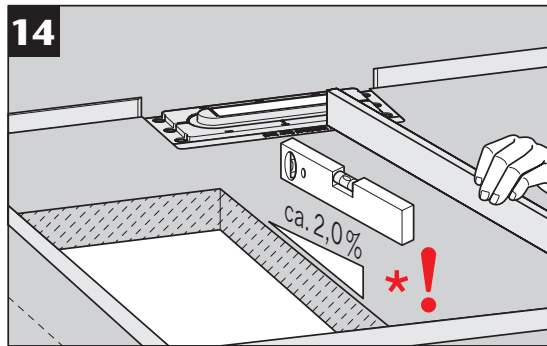
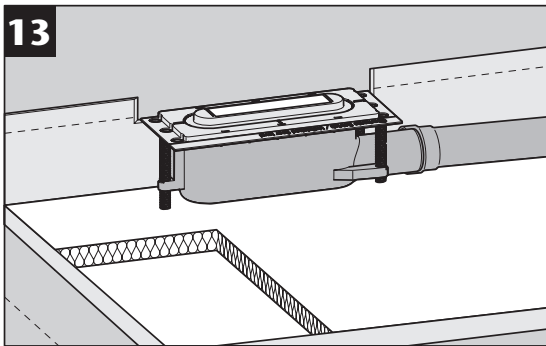

Габариты		
L [mm]	B [mm]	H [mm]
800	55	12
900		
1000		
1200		

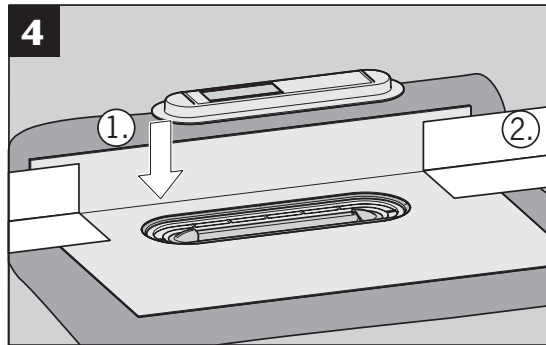
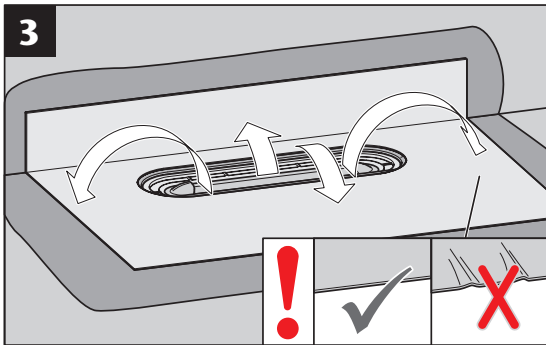
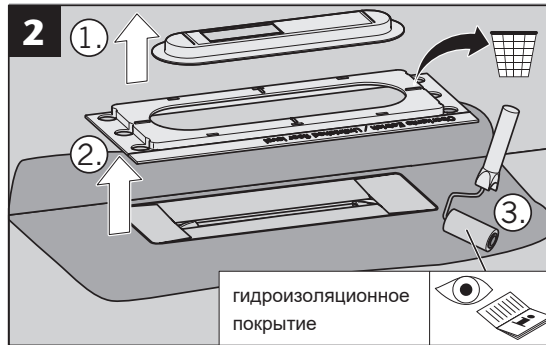
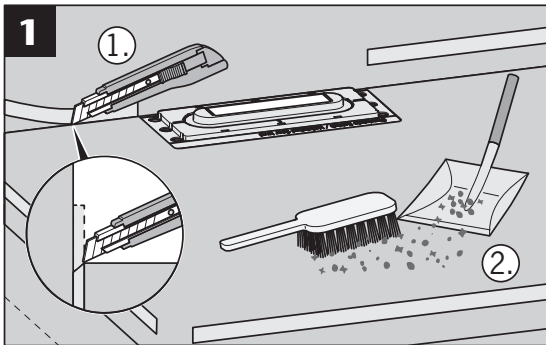
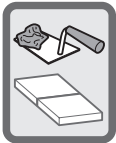

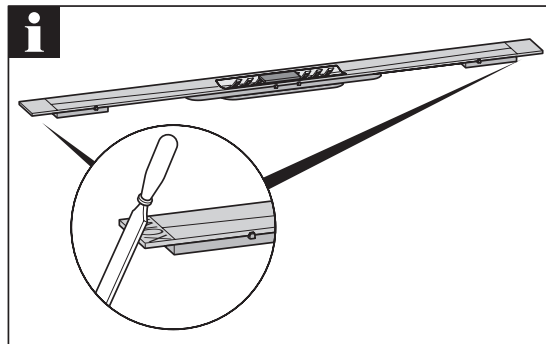
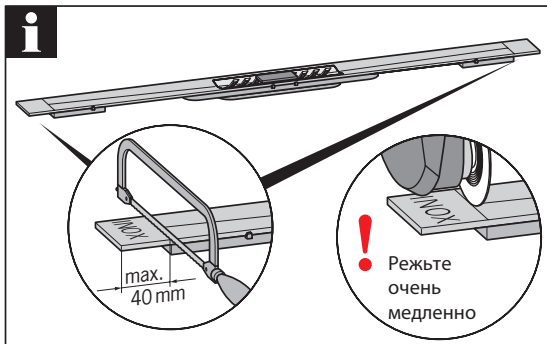
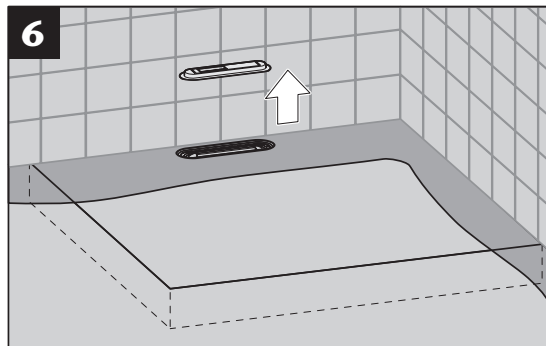
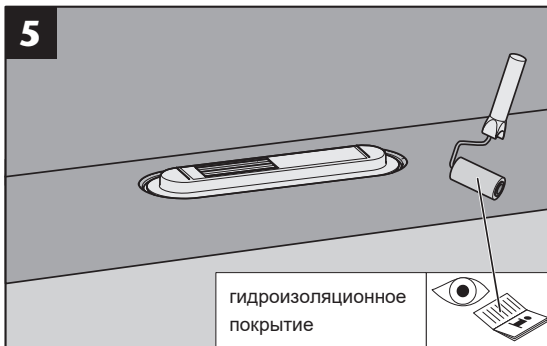
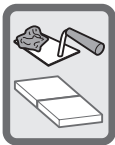

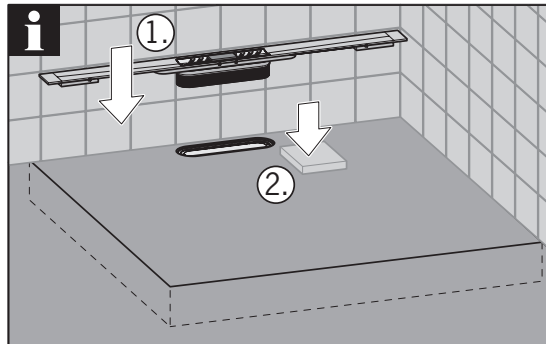
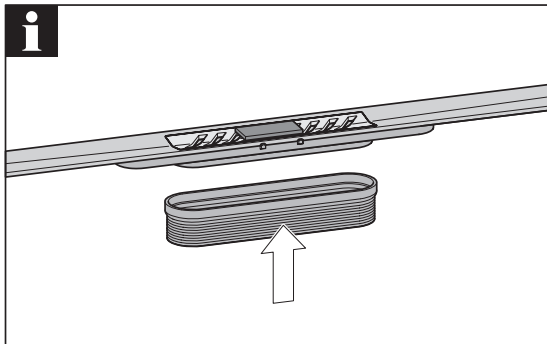
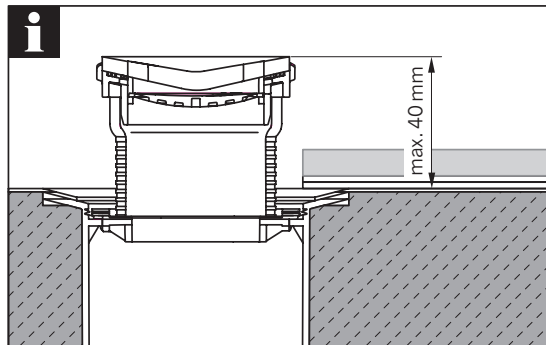
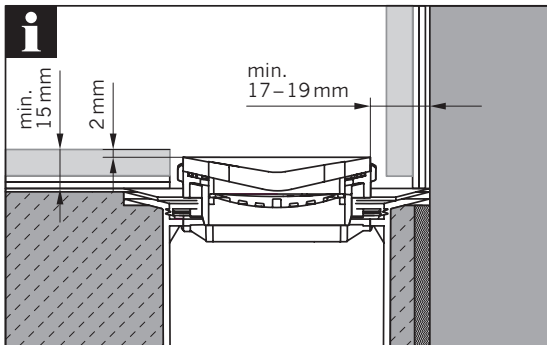
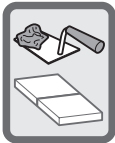

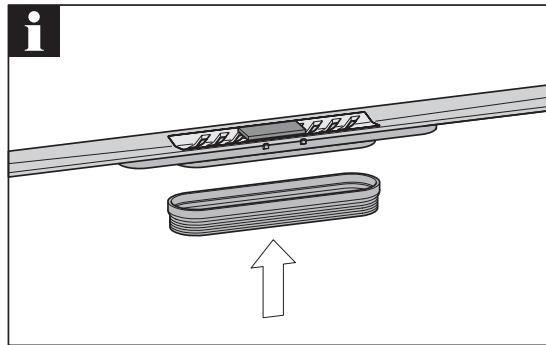
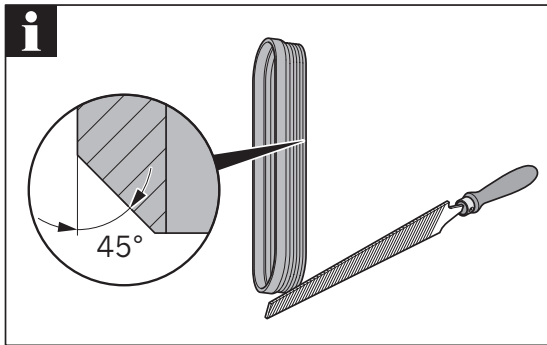
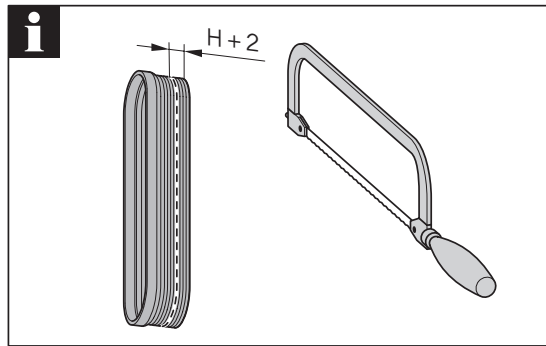
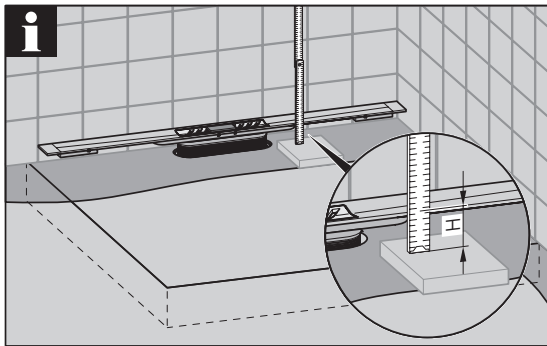
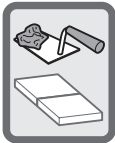

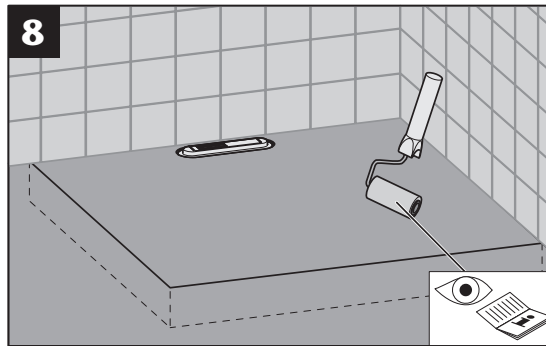
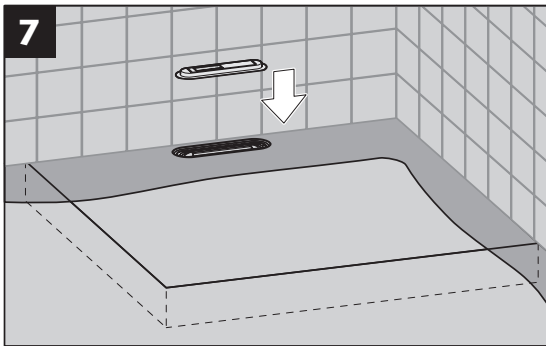
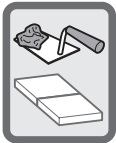

- * Hohlraumfrei unterfüttern
- * Lining without cavities

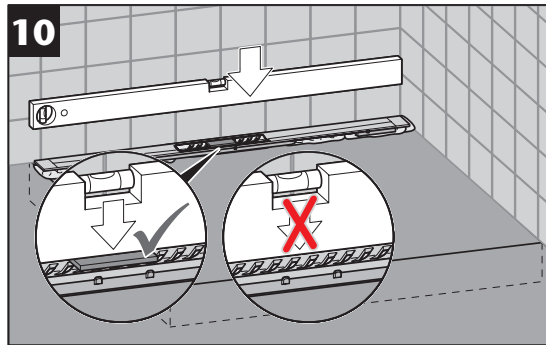
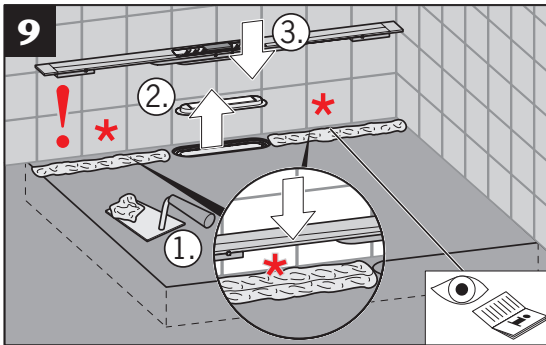

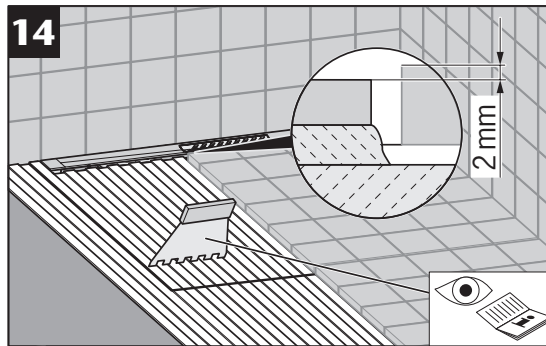
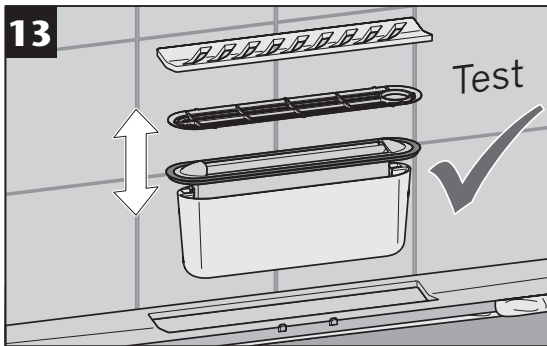
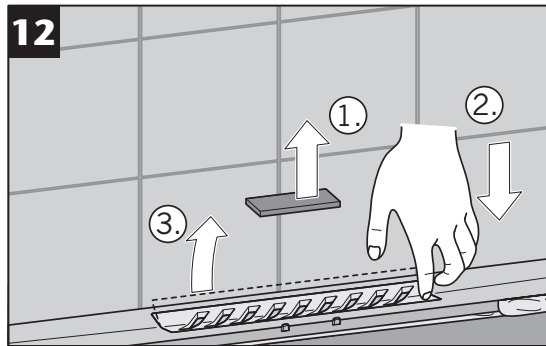
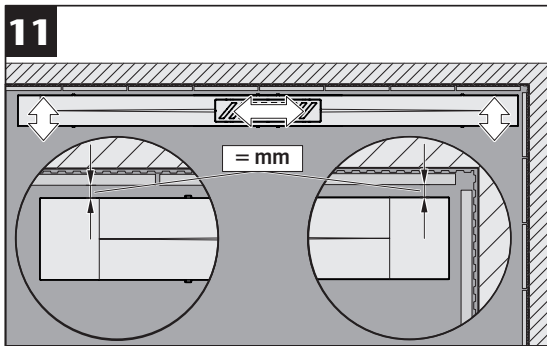
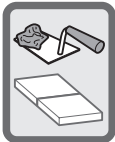

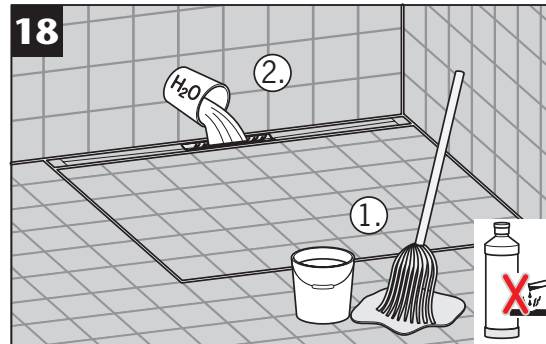
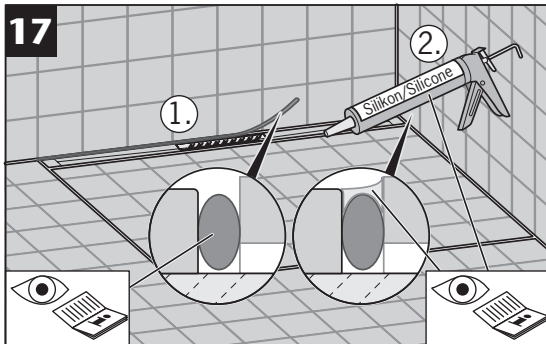
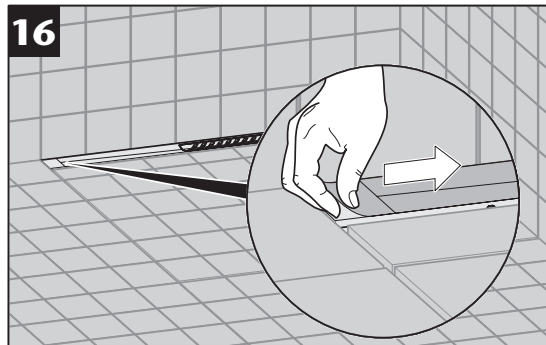
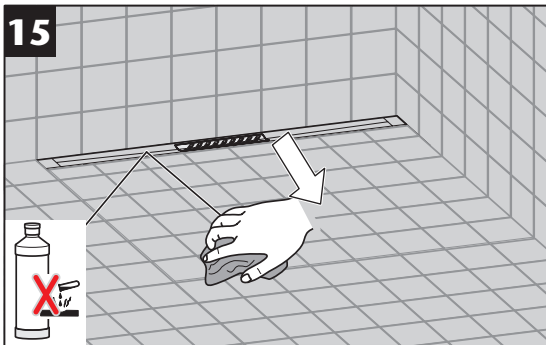
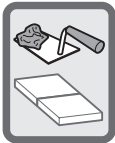

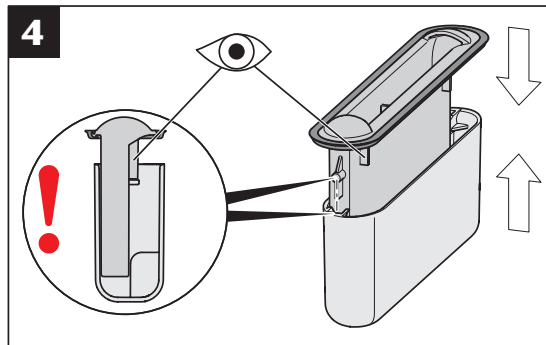
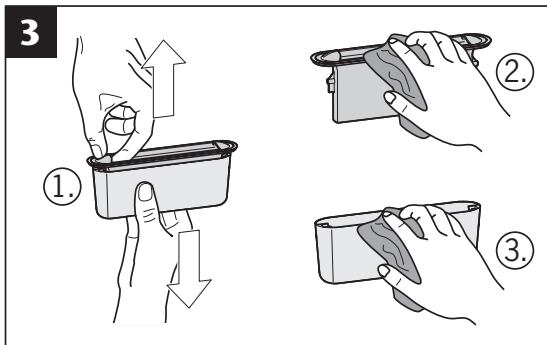
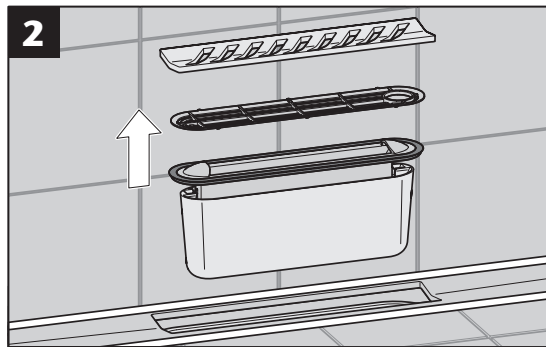
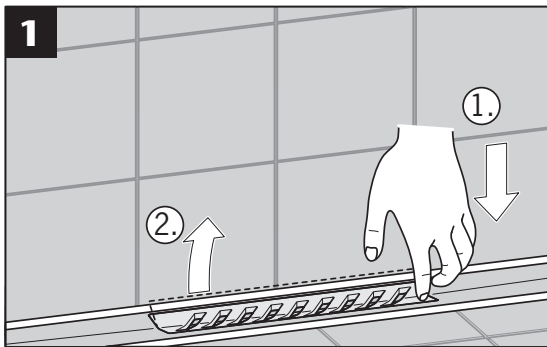

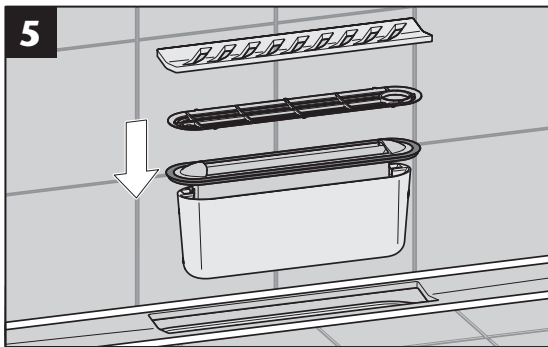



www.acorussia.ru

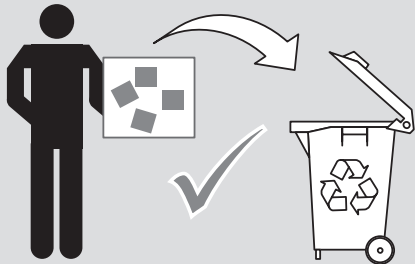

0850.10.76 V 1.2